

### MAIL ISSUES

Mail theft has been on the rise in the area, not only in Greentrees but in the Florence and Mapleton communities, as well. In some cases, incoming or outgoing checks are stolen and ‘washed’ or ‘bleached,’ and a new payee and amount are entered; these checks can be and are cashed since they are actual checks. According to an article in a recent AARP publication, the thieves are now ‘check cooking’: using technology to scan or take a photo of checks, altering them with some readily available software, then either print them or use the banks’ mobile apps to deposit the checks.

Even if you don’t receive or send checks in outgoing mail, the thieves can get a lot of personal information from your mail. Bank and credit card statements have your account numbers, names, and balances. Retirement statements have your income. Even newsletters and mailings from your old employers can give thieves information you may not want out and can help them steal from you.

While we may not stop these thieves completely, there are some things that we can do ourselves to help prevent your incoming and outgoing mail from being stolen. Please see tips on ways to protect your incoming mail on page 13. These tips won’t prevent theft from totally happening – thieves always are one step ahead of us! But they will help as much as we can to limit it.

At Greentrees, the board is investigating ways to help. We have received an outgoing mail tote from the Post Office. This tote is in the office for you to place your outgoing mail in if you wish.

Diana Lindsley



### REMINDER ON HOA DUES

HOA dues are \$270/month as of January 2024. The last day to pay without receiving a late fee and adding interest is the 25th of each month.

### Greentrees Village Water Service Modification Project

City of Florence Public Works staff along with RH2 Engineering has been preparing for a much-needed project to replace the existing water meter and service piping to the Greentrees West subdivision. The work has been approved and we are waiting on word for timing of the project. When the city was here for the Rhody Project on April 4<sup>th</sup>, they mentioned that it would start in approximately 6 weeks and would last about 3 weeks. According to this, it should begin in mid-May. Keep an eye out in our weekly email blasts for updates on this. If you are not on our weekly email blasts, please contact Diana Lindsley.

### INSIDE THIS ISSUE

New Management Team	2
Volunteers—Jeff Myers and Fred Burns	3
Bear Proof Trashcans	4
Mother’s Day Lunch	4
Florence Feud Update	5
President’s Message	6
ACC Reminder	7
GERT	7
Group Corner	8
At The Movies	9
Volunteer Opportunities	10
Dogs! Dogs! Dogs!	12
Calling All Artists	12
Poem By Sally Daugherty	12
Tips On Mail Fraud	13
Rhody Drive Project Update	14
In Praise of Reading	15
Women Build	15
Pet Of The Month	16
Rhody Days!	16

**OFFICE MANAGER  
KIMBERLY WRIGHT**

Our new Office Manager Kimberly Wright, started as Office Assistant in GTV in November 2023. She has been absolutely indispensable in bringing order out of chaos in the office, and taking on more and more responsibility daily. It's a good thing she "enjoys getting in the trenches and learning from the bottom up". She spent nearly five years in the Marine Corps, including a stint during Desert Storm. In her military career, she often served as Squad Leader over a group of folks who mostly outranked her.

Kimberly's corporate career was as a business analyst. She started with small projects, then worked her way up to managing multiple project managers. She's adept at all modern business systems, can plan, execute and meet deadlines, as well as delegate when necessary.

Kimberly's eyes light up when she lists her priorities for the near term at GTV. On her to-do list are projects she's already begun: bringing the delinquent accounts current; finishing clean up of Door King (gate and fob system) to enable reports; getting the office fully staffed; and getting all the office systems set up electronically. After that, she hopes to establish ACH payments, organize and scan lot files, and create a Document Retention Policy.

Asked what she'd like to say to GTV residents, she replied: "Our business is to do Greentrees Village business, using best business practices." She wants residents to know she's working for them. She's looking forward to working as a team with James.

Nancy O'Neill

**FACILITIES MANAGER  
JAMES TENNISON**



That new Facilities Manager we hired? He's new to the management team, but not to Greentrees. James has been on the maintenance staff here for 8 years and took over as supervisor at the beginning of the year. James has passed several man-

agement and HOA administration classes and feels well qualified for his new role. He has worked his way up to manager in every job he's had. His experience in GTV is varied and valuable.

James' top priorities as Facilities Manager for GTV are: to provide a safe park for residents, employees and visitors; to bring GTV up to date using technology to enhance security; to get the pool maintenance automated to free up staff now spending hours doing it manually; to educate residents about the Rules and Regulations; and to manage the Issues of Concern in a timely and fair manner. He has an easy-going manner and is open to suggestions and input.

James was born and raised in Mapleton. He and his wife, Bambie, are parents of two sons, one of whom, Aaron, is following his father's footsteps as a maintenance worker here in GTV. James is looking forward to meeting everyone in Greentrees. He wants us all to know that he wants to improve our village in every way he can within the budget.

Nancy O'Neill

**GENERAL CONTRACTOR**

RESTORATION ROOFING

DECKING HANDYMAN FENCING

FLOORING ROT REPAIR

DEAN JOHNSON  
CCB#238517

**JOHNSON'S**  
HOME SERVICES LLC

541-508-6982

Wishing all of our friends at Greentrees a happy Spring!

Come enjoy the sun while you wander through our garden, relax by the Koi pond, and browse the gift shop!

**LAUREL BAY GARDENS**

M-Sat 8:30-5:30 Sun 10:00-5:00  
88493 Hwy 101  
541-997-5973



## VOLUNTEER—JEFF MYERS



You hear him on the microphone at events; calling out tables to come serve, reminding people to purchase tickets for the bike or quilt raffle, and making sure things are flowing smoothly. Jeff Myers has been a resident of Greentrees Village since 2004 when he moved here with his wife. Unfortunately, she passed away 2 short years later.

In addition to being the voice of our events, Jeff has served on the Board twice and is a member of the Properties (past chair), Architectural Control and Activities Committees. He is in charge of the bottle and can recycling, which funds community events.

Jeff is an avid cyclist, having logged thousands of miles on roads and trails. He rode in the very first Cycle Oregon event! Jeff was also part owner of the Florence 101 Cycle shop. He does less biking now; instead he likes to walk on the trails and beaches around Florence.

Prior to retirement, Jeff had a 15-year career as an industrial blacksmith, where he made steel parts that were used to construct the dams in the Columbia and Snake Rivers. He also worked as a garbage truck driver and apartment maintenance.

Jeff has two grown children and three grandchildren. When his children were young, Jeff was a Cub Scout leader and soccer coach. His grandson is taking after Grandpa by becoming a talented trail rider.

Diana Lindsley

## VOLUNTEER—FRED BURNS



A wonderful man, who reminds me of my own father, Fred Burns, 88 years young, has been around Greentrees and served on the Board as President and VP, and Committees for several years. He was raised in Long Beach, CA. While attending college there, he met and married his beautiful bride, Sharon, in 1958. They raised 3 wonderful sons, one of whom has passed away. They have 6 grandchildren and 9 great-grandchildren.

Fred studied Industrial Drafting in college and worked on the Apollo Program as a draftsman. He then got involved in law enforcement and worked as a sheriff for 4 years, then as a police chief for 4 years, before becoming a Criminal Investigator for the Idaho Bureau of Investigations from 1989-1997, when he retired. While waiting for Sharon to retire, he decided to go back to work as in the U.S. Marshall's office for 4 years.

In 2003, Fred and Sharon sold their home and travelled for 5 years in their RV. They hosted many Oregon State Campgrounds during this time and hosted Honeyman State Campgrounds several times. They loved the area and decided in 2008 to buy their lot in Greentrees and have been here ever since.

Volunteering at Greentrees is not the only volunteering Fred has or is doing. He has been an Honor Guard of VFW and a Post Commander for 2 years. He is also a member of Disabled American Vets and American Legion. He is a member of Cooties, which are known as the Honor Degree of the VFW.

In his spare time, Fred enjoys doing needlepoint.

Diane Greer

## BEAR PROOF TRASHCANS

We've had a lot of problems with bears getting into garbage cans lately. County Transfer offers **Bear Proof cans**. The cost of these cans is \$10 a month, which is billed quarterly at \$30 per billing cycle. You must call them at 541-997-8233 to set up an individual account. If you don't have a secure place to store your garbage, this is a really good idea. If you put your garbage out the night before garbage day and a bear or other animal gets into it you will be fined if it happens repeatedly. Remember, garbage day is every Monday except Christmas if it falls on a Monday.

James Tennison

## MOTHER'S DAY LUNCHEON



The GTV Board will be hosting the Mother's Day Luncheon to honor all mothers. We will be serving a luncheon of lasagna, salad, garlic bread, cake and beverage on **Sunday, May 12** beginning at 1 PM. Lunch for mothers is free while **spouses and guests are \$7 each**.

The signup sheet is in the library; please signup by May 6th, so we can purchase and cook enough food for everyone.

If you are home bound and would like a meal delivered to you, please contact Diana Lindsley at 541-590-3623 or [tciana@comcast.net](mailto:tciana@comcast.net) to get on the list.

*"A mother's hug lasts long after she lets go."*  
—Unknown

*"A mother's happiness is like a beacon, lighting up the future but reflected also on the past in the guise of fond memories."*  
—Honore de Balzac

Let us be your hands

541.902.3140  
Improvementy@gmail.com

Carlo's Yard Improvement

Lawn Mowing, Gutter Cleaning, Power Washing, Yard Maintenance, & More...

Florence Oregon 97439  
License # 45724

My pleasure is working 4 you

Aloha Coastal Notary, LLC

**Alisha R. Hill**  
Certified Signing Agent  
& Mobile Notary Public

Office 541-991-3264  
Cell 541-901-1847  
[AlohaCoastalNotary@gmail.com](mailto:AlohaCoastalNotary@gmail.com)

[AlohaCoastalNotary.com](http://AlohaCoastalNotary.com)

CERTIFIED Notary Signing Agent  
MEMBER NATIONAL ASSOCIATION OF Notaries  
CERTIFIED Notary Signing Agent  
TRAINED

Power of Attorney  
Advance Directives  
Trust and Wills  
Title and Loan Docs

Proud Member of the  
**Florence** OREGON COAST  
Area Chamber of Commerce



*IN MEMORIAM*

David Robinson—659

## VOLUNTEERS

Let us know which volunteers you would like to read about in the June Village Voice.



Have Docs? Will Travel!  
Sign from the comfort  
of your home or  
local business!

\*\*\*A Notary Public is **NOT** a Lawyer. I am not an attorney licensed to practice law. I am not allowed to draft legal records, give advice on legal matters, including immigration, or charge a fee for those activities.\*\*\*

Bonded & Insured

Family Owned

**Marshalls Maintenance**

Sewer & Drain Cleaning  
Dryer Vent Cleaning

(775) 340-2120

More than 30 years experience in household repair



## FLORENCE FOOD SHARE FUNDRAISER

### FLORENCE FEUD—UPDATE

On Friday, April 5, five members of the GTV board went head-to-head against board members from Florentine Estates in the Florence Feud at Three Rivers Casino. GTV won against Florentine and moved on to the lightning round where they scored points against the other winners of the head-to-head games. All-in-all there were 8 teams playing: GTV; Florentine Estates; Western Lane Fire & EMS; Three Rivers Casino Resort and 4 teams made up of prominent people in the Florence Community, including some city officials. There were 4 teams that went to the lightning round and GTV came in 2nd.

This was a fund raiser to support Florence Food Share (FFS). It turned out to be a successful event and they plan to do it again next year. The event sold out and there was a silent auction, which also helped in collecting funds for FFS. In the picture below are our Greentrees contestants: from left to right—Diane Greer, Jack Swanson, Leslie Shaw, Mike Peaslee and Sally Ott.

The money raised supports the basic operations of the FFS, as well as any building needs or architectural needs that aren't covered by grants. Unfortunately, FFS can't fund their program by grants alone, so this fundraising is greatly needed and was a lot of fun.

FFS has multiple volunteer opportunities—helping the clients, working in the warehouse, or working in the garden. Donations of money and food staples are always welcome. If you happen to be cleaning out your pantry, the FFS will gladly take any unopened items as long as the expiration date is no more than 3 years past. So, if you are moving to a retirement home or assisted living, please don't throw away any unopened items. Please have them taken to FFS.

If you are interested in volunteering or donating, please contact FFS. The need in Florence has grown tremendously over the last few years.

Diane Greer

F  
L  
O  
R  
E  
N  
C  
E

F  
E  
U  
D

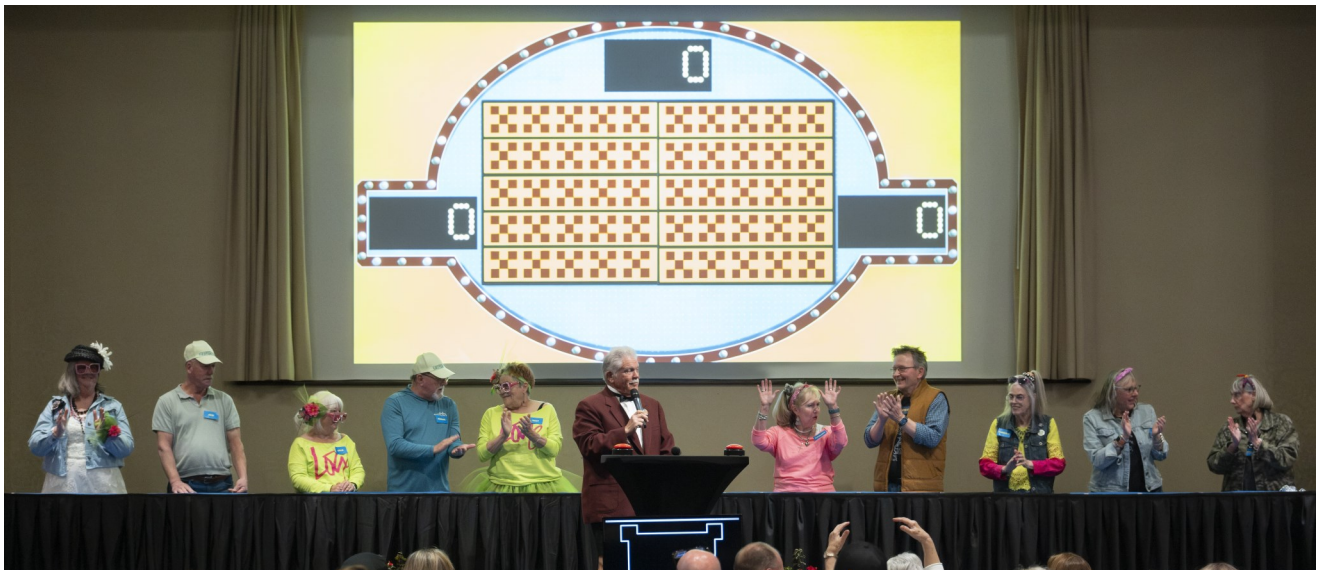

Surfperch Mobile Notary

Wendy Dillard

541-901-9577

surfperchmobilenotary@gmail.com

www.surfperchmobilenotary.com



**LOFY CONSTRUCTION LLC**

**FLORENCE, OREGON**

**SERVING FLORENCE FOR 30 YEARS**

**(541)-590-3691**

**GENERAL CONTRACTOR**

**REMODELS, REPAIRS**

**AND CUSTOM WORK**

**C.C.B. 221760**

## PRESIDENT'S MESSAGE

Dear fellow residents,

We have great news! Because the March Board meeting was interrupted, you may have missed that we voted to approve two promotions. James Tennison is now our Facilities Manager and Kimberly Wright is now our Office Manager. We are lucky to have them.

Pat Cowgill, our Bookkeeper has agreed to stay! I am very pleased to announce that together with the Finance Committee's help, Pat is up to speed and our books are in great shape. Not only that, but the long awaited audit will finally commence!

Kimberly has hired our Office Assistant! Deb Griffin started on Monday 4/22/24. With this new hire, employment at Greentrees Village is complete!

Maintenance has been supplied a cellphone with an unlimited data plan, so that no matter where they are, they can call 911, take photos, be "in touch" with management and keep their fingers on the pulse of Greentrees Village! They also have new strong flashlights! All the things they need to do their very best for us.

If you've been avoiding the office for a while, please come back and see for yourself what a welcoming, friendly and helpful environment you'll find there. We're returning your phone calls quickly, answering your questions, rules are being enforced according to our procedures in the Rules & Regulations packet, and we're addressing your Issues of Concern and resolving them, following procedures in the same Rules & Regulations packet. If you don't have a packet, please come to the office for one. With Pat's help we're also getting the old statement errors corrected and our very own Sally Ott, the Vice President of the board is helping by make phone calls to those of you who may have forgotten to update your banks with this year's dues amount or anything else that can help us all run a better, happier Greentrees.

Christine, Greentrees own Letter Carrier, has kept us in the loop regarding stolen mail. On Monday, she was delivering what must have been stolen and now found mail, and she said most seemed to be outgoing mail from the office. If you get duplicates, please forgive the process. It would appear that the Florence Police Department is making great strides in solving these cases! What a wonderful place we get to call home.

Fondly, Carley Scibetta



stitch &  
sole

clothing . shoes . style .

1377 Bay Street Old Town Florence

[www.stitchandsole.com](http://www.stitchandsole.com)

Thank you for shopping local

New Styles Arriving Daily

**10% OFF**

**YOUR ENTIRE**

**PURCHASE**

LIMITED TO STOCK ON HAND  
Exp 5/31/2024  
Excludes Sale Items

## ARCHITECTURAL CONTROL COMMITTEE (ACC) REMINDER

This is the time that people start trimming their shrubbery and doing their yard work. Lot owners need to remember that we have dumpsters for resident's lot trimmings. The trimmings must be no longer than 3 feet in length and 6 inches in diameter. Please be courteous about the amount you place in the dumpster. They are not there for your whole lot clearing. Pickup loads should go to the dump. Residents who use contractors, please be sure that they carry your load away to the dump. If those loads are deposited in the dumpster you, the resident can get a fine.

Please don't throw any clippings or debris in the commons. That can result in a fine as well. For any clearing or cleaning out of the greenbelt, please talk to your neighbor about your plans, so they are prepared when they see you do the work. Neighbors need to understand that the owner has the right to clear their greenbelt and then replant with trees or shrubbery of their choice.

If you are considering construction projects around your house, you must first contact the ACC committee to see if you need a permit. Some projects require a City permit as well as a Greentrees permit. Let's all work together to make Greentrees a beautiful place to live.

Your Architectual Committee / Nick Woodworth

## GREENTREES EMERGENCY RESPONSE TEAM

Who is Greentrees Emergency Response Team 'GERT'?

None other than our amazing residents, who are dedicated to helping out our Greentrees community in the event of a disaster. These amazing volunteers spend their time to make our community stronger and safer.



GERT educates residents in basic disaster response skills, team building, emergency radio communications, search and rescue, basic disaster medical, fire safety, CPR and pet preparedness.

GERT is a dedicated group of residents that have a common goal: how to better prepare for hazards that may affect our community.

Prepare, Not Scare!

GERT meets on the second Thursday of each month at 1 pm in the Multipurpose room.

Any questions, contact our GERT Trainer/Coordinator, Kristel Buechner @ 541-997-0909.

Kristel Buechner

**BERKSHIRE  
HATHAWAY**  
HOMESERVICES

NORTHWEST  
REAL ESTATE

**Florence Office**  
Licensed in the State of Oregon

*Florence is a place you'll want to play, stay, and grow.  
We're here to meet all your Real Estate needs.*

Annette Prater  
Real Estate Broker  
Cell: 541-999-0179



JaNell Earley  
Real Estate Broker  
Cell: 541-999-1543



PO Box 276, 1875 Hwy 101  
Florence, OR 97439



# GROUP CORNER

**NEW! Knit / Crochet Group.** The NEW Knit & Crochet group will begin meeting on the first Friday of each month in the Multi Purpose Room at 1 PM. All knitters and crocheters welcome! Please contact Carol Parrish for more information.

**Luncheon out!** – This group meets at local restaurants at 11:30am usually on the 3<sup>rd</sup> Wednesday of each month, unless otherwise noted. This month they are meeting on May 15, at Clawson's Wheelhouse at 11:30 AM. The signup sheet is in the library. Contact Jude Stendahl at 763-792-2312 for any questions. All are welcome to attend!

**Scrapbooking / Papercrafting Group!** Papercrafting / scrapbooking has been extended into the summer. Meetings will generally be on the 3<sup>rd</sup> Sunday of the month in the Rec Hall. Meeting May 5 in the Rec Hall from 10 AM – 2 PM. Contact Joy at [jplummergang2015@gmail.com](mailto:jplummergang2015@gmail.com) for information or to attend.

**Acoustic Guitar Jam** – The informal 'jam' sessions will be every Thursday at 10AM in the Multi-Purpose room (2<sup>nd</sup> Thursday in the Rec Hall). Playing mostly a "seasoned" variety of folk, rock, and country music, we attempt some strummin', pickin', and singin'. Bring your wooden box with strings and share some music. Contact: Dan Chagnon, 541-621-6293.

**Pickle Ball** – This is a small group that meets at 8:30 AM every Monday, Wednesday, and Friday. They encourage anyone who wants to learn the game to come, watch, and learn. Extra paddles are available.

**Quilt Group** – We will continue to make lap quilts for the Christmas Giving Tree. Regular meetings will be in the Multi-Purpose Room from 10 AM - 12 noon, meeting the 3<sup>rd</sup> Friday of the month. Next meeting – May 17. All abilities are welcome! If you would like to donate supplies, we'd love to have them. We will make easy blocks and put together quilts for the children of Florence. Please contact Diana Lindsley at 541-590-3623 for more information.

**Book Club** – This group meets at 2PM on the 4<sup>th</sup> Thursday of each month in the Multipurpose Room. Rather than everyone reading the same book, each month members are encouraged to bring a book that they have read or are reading. For more information, please contact Charles Lugg at 541-590-3871 or Don McGehe at 541-590-3421.

**Other Groups?** – If you belong to a group and would like to share your group information, please contact Diana Lindsley at 541-590-3623 to get your group activities added to the Group Corner section.

## COASTAL HOME SERVICES

*Professional, quality services for your home*



- Gutter Cleaning • Duct Cleaning
- Dryer Vent Cleaning
- Pressure Washing & Much More!

CCB 221760

**541-590-7027**

[coastalhomeservicesflorence.com](http://coastalhomeservicesflorence.com)



*“There is no influence so powerful as that of the mother.” – Sara Josepha Hale*

*“The world needs our mothers.” – Liya Kebede*



# AT THE MOVIES



By Jim Negri

The Genre for this month is **COMEDY**

**Porky's – 1981** High school friends Pee Wee (Dan Monahan), Tommy (Wyatt Knight), Billy (Mark Herrier), and Mickey (Roger Wilson) want to lose their virginity. But when they're kicked out of a strip club after the owner, Porky (Chuck Mitchell), takes their money, they plot revenge. While they try to get back at him, they deal with other teen troubles, including Pee Wee's worries that his "equipment" is shrinking, their sexually opinionated gym teacher (Kim Cattrall), and a spy hole in the girl's locker room.

**Scary Movie 4 -- 2006** Dim-witted Cindy Campbell (Anna Faris) and her sex-crazed friend, Brenda (Regina Hall), team up with cute-but-clueless Tom Ryan (Craig Bierko) to save the world from a hostile alien invasion, with hints of "War of the Worlds," "Saw II," "Million Dollar Baby" and "The Village." Celebrity cameos include Carmen Electra, Shaquille O'Neal, Dr. Phil McGraw, Bill Pullman, Molly Shannon, and Michael Madsen.

**Sitting Pretty -- 1948** The film stars Robert Young, Maureen O'Hara, and Clifton Webb, about a family who hires the mysterious Lynn Belvedere to babysit their rowdy children.

**Miami Rhapsody -- 1995** Even though Gwyn Marcus (Sarah Jessica Parker) is engaged to her boyfriend, Matt (Gil Bellows), she is still afraid of commitment. While she admires her parents' loving relationship, she discovers that her family has not always been faithful in marriage, making it harder than ever to settle down. As her mother (Mia Farrow) pressures her to get married, and plenty of attractive men appear in her life, Gwyn learns that she must balance her career, relationships and marriage to be truly happy.

**Tooth Fairy -- 2010** A bad deed on the part of a tough minor-league hockey player results in an unusual sentence: he must serve one week as a real-life Tooth Fairy

**Willy Wonka and the Chocolate Factory -- 1971** A sweet boy from a poor family dreams of finding one of five golden tickets hidden inside chocolate bar wrappers which will admit him to the eccentric and reclusive Willy Wonka's magical factory. One after another, tickets are discovered by ghastly children - but will the lad find the last remaining one and have all his dreams come true?

**Young Frankenstein -- 1974** Respected medical lecturer Dr. Frederick Frankenstein (Gene Wilder) learns that he has inherited his infamous grandfather's estate in Transylvania. Arriving at the castle, Dr. Frankenstein soon begins to recreate his grandfather's experiments with the help of servants Igor (Marty Feldman), Inga (Teri Garr), and the fearsome Frau Blücher (Cloris Leachman). After he creates his own monster (Peter Boyle), new complications ensue with the arrival of the doctor's fiancée, Elizabeth (Madelaine Kahn).

**Agent Cody Banks -- 2003** Agent Cody Banks is a 2003 American spy action-comedy film directed by Harald Zwart. The film follows the adventures of the 15-year-old title character, played by Frankie Muniz, who has to finish his chores, avoid getting grounded, and save the world by going undercover for the CIA as a James Bond-type superspy. Hilary Duff, Angie Harmon, Keith David, Cynthia Stevenson, Daniel Roebuck, Darrell Hammond, Ian McShane, and Arnold Vosloo co-star.

**Alvin and the Chipmunks -- 2007** After the tree they called home is cut down and shipped to Los Angeles, talking chipmunks Alvin, Simon, and Theodore find a new home with songwriter Dave Seville (Jason Lee). Despite a rocky start to this new arrangement, Dave eventually discovers that the spunky critters have rare singing talent. When the three perform in front of record executive Ian Hawke (David Cross), he immediately signs them. Although the infectious group rapidly gains in popularity, their loyalty is soon tested.

**Analyze This -- 1999** A Mafia don suffers anxiety attacks which force him to visit a psychiatrist. Renowned for his brutality, the mobster is worried about his reputation when he finds himself bursting into tears for no apparent reason. Seeking help on the psychiatrist's couch, the forceful and demanding hard man proves a challenge to the doctor who has several complicated problems of his own.

## VOLUNTEER OPPORTUNITIES

### Join a Committee Or Help Out In Other Ways

As Patsy Turner says "Just try it! Jump in with both feet.  
If you don't like it you can find something else."

#### Committees

Activities  
Architectural Control (ACC)  
Bingo  
Communications  
Finance  
Properties  
Acoustic Guitar Jam  
Bingo Helpers  
Book Club  
Bunco Coordinator (filled)  
Chef  
Christmas Tree Decorator  
Coffee Meet & Greet  
Community Helping Community  
(dog walking, driving people, etc.)  
Cook  
Decorator  
Display Cabinet Coordinator  
DVD Librarian (filled)  
Email Blast (filled)  
Exercise Coordinator/Instructor (filled)  
Exercise Helper  
Facebook Administrator (filled)  
Flea Market Coordinator  
Flea Market Helper  
Flea Market Raffle Coordinator  
GERT Radio Group  
Game Night Coordinator  
Kitchen Helper  
Librarian (filled)  
Luncheon Out Coordinator (filled)  
Photographer  
Potluck Host  
Quilt Group Coordinator (filled)  
Recording Secretary (filled)  
RV Camp Host (filled)  
Scrapbooking/Paper Crafting Group  
Shop Monitor (filled)  
String Instrument Class Coordinator (filled)  
Toys for Kids Drive Coordinator (filled)  
Village Voice Editor (filled)

Village Voice Contributor  
Village Voice Folding Crew  
Village Voice Writer  
Webmaster (filled)  
WLEOG Representative (filled)  
Or anything else you want to volunteer for  
**To Volunteer Contact Diane Greer**  
**661-706-1669 Diane.M.Greer@gmail.com**

*Best for Hearing is hearing healthcare at its finest! With over 40 years of experience, Best for Hearing in Florence is your best choice for hearing tests, hearing devices and even sound protection. We offer a wide array of services to help you and your loved ones hear better!*

*Call or stop by today to make an appointment.  
541-997-8866*



Featuring products by:



**BEST FOR HEARING 2285 HWY 101 SUITE M**  
(Adjacent to St. Vinnie's in Coastal Fitness Plaza)

Landscape • Design • Install



**541.999.7761**

[hollowaylandscaping@outlook.com](mailto:hollowaylandscaping@outlook.com)

OLCB#9906  
LICENSED, BONDED, & INSURED

**Landscape Construction**  
**Decorative Concrete/Slabs/Walkways**  
**Tree Removal & Stump Grinding**  
**Fencing & Dog Runs**  
**Sod & Artificial Turf**  
**New Sprinkler Systems**  
**Drainage & Grading**  
**Retaining walls**  
**Water Features**

 [/HollowayLandscaping](https://www.facebook.com/HollowayLandscaping)  
[hollowaylandscapeconstruction.com](http://hollowaylandscapeconstruction.com)



**For all your Selling, Buying & Financing Needs-  
We got you covered!**



**SADIE  
WARD**

REAL ESTATE BROKER  
C: 541.999.7119  
SADIE@CBCOCAST.COM



**COLDWELL  
BANKER**  
COAST  
REAL ESTATE

**Just SOLD in 8 day over asking**



**1600 Rhododendron Dr  
#45  
\$280,000**

**1 bed 1 bath  
390 sqft**



**Beth Rudometkin**

Senior, Certified Mortgage Advisor  
NMLS: 811660

**o: (541) 743-2978**

**c: (707) 486-8744**

**f: (541) 940-7719**

[beth.rudometkin@apmortgage.com](mailto:beth.rudometkin@apmortgage.com)



*Different name, same great service & still doggone reliable!*

**Florence Branch** | 244 Maple Street | Florence, OR 97439 | NMLS-1850

Licensed in OR and I.A.

Our team is able to help you in OR, WA, CA, AZ, MT, NV, WY, ID, CO, & TX!



Scan QR code to apply!



**Life in reverse...financial longevity and peace of mind!**



**Debbie Tallman**

Reverse Mortgage Advisor

NMLS: 248704

**o: (541) 213-2989**

**c: (541) 390-0934**

**f: (541) 940-7716**

[debbie.tallman@apmortgage.com](mailto:debbie.tallman@apmortgage.com)



NMLS: 1850

**Bend Branch** | 233 SW Wilson Avenue | Suite 102 | Bend, OR 97702

**Formerly known as Finance of America Mortgage.**

## DOGS! DOGS! DOGS!

You may have seen me walking my 2 dogs through Greentrees. The reddish brown Plott Hound, Emmy and the gray Poodle mix, Cutie Pie. People tell me, "What good dogs you have." They weren't born good, I had to train them. Just like you train your kids to brush their teeth and tie their shoes, say "Thank you," and "Please," dogs need to be taught to be good citizens also.

The American Kennel Club has an expert-made training program designed to help you and your dog be the best you can be together. In fact it's called the Canine Good Citizens program and test. You can take classes or do the training on your own, but I'll list the 10 things on the test. Both of my dogs passed. It was a requirement before they could start their Therapy Dog training. They passed that, too and loved doing therapy work for several years in Coos Bay.

- Accept a friendly stranger.
- Sitting politely for petting.
- Appearance and grooming.
- Out for a walk on a loose lead.
- Walking through a crowd.
- Sit and down on cue and stay in place.
- Come when called.
- Reaction to another dog.
- Reaction to a distraction.
- Supervised separation.

Could your dog pass? If not, you may have some work to do!

Bonnie Costa

## CALLING ALL ARTISTS

The Village Voice announces two new sections to our newsletter: Pet of the Month and Artistic Section.

The new Artistic Section will be a place for residents to share their art, poems, crafts, and other creations. Please send your submissions to [gtvwebmaster57@gmail.com](mailto:gtvwebmaster57@gmail.com) about items you wish to share no later than the 16th of the month for consideration in our next month's newsletter.

This month, long time resident Sally Daugherty shares a poem. Sally has been a resident of GTV for almost 20 years and lives on the west side. She developed her interest in poetry after retirement and has found much inspiration here in GTV. Sally is very happy to be the first contributor to our Artistic Section and looks forward to seeing what others contribute.

She welcomes dialogue with others who are interested in poetry and would like us to know about Florence Regional Art Alliance (FRAA). It is located at 120 Maple St in Old Town Florence.

On the first Tuesday of each month there is an "Open Mic" poetry reading at FRAA from 7 to 8:30 pm. Anyone is welcome to come listen and perhaps read a selection of their poetry. You must first sign in to reserve a spot to read. There is no fee and refreshments are often available.

On the last Tuesday of the month there is a "workshop" at FRAA for aspiring poets to help sharpen their skills within a group environment. It lasts from 6:30 to 7:30 pm. There is no charge.

Diane Greer

## POEM

**By Sally Daugherty**

It's late summer,  
With days getting shorter  
Shadows longer.  
Workmen must hurry now.  
Sunny days won't last

Much longer. Oh  
How I love Greentrees  
Dressed for fall,  
One last flower bouquet  
A colorful leaf drifting

Hot dog toasting  
Children swimming, laughing  
And dunes buzzing  
Celebrating together  
Cheering our favorite team

Geese high above  
Honking to each other  
Goblins dressed up

*"Character is power." —  
Booker T. Washington*

## FAVORITE RECIPE OF THE POTLUCK

Come to the next potluck and see if your dish is voted the favorite to get your recipe in the next month's newsletter. Connie and Jim Betson's dish was voted the favorite. Look for their recipe in the June newsletter.



## TIPS ON MAIL FRAUD

- Check your mail daily. Leaving mail in your mailbox overnight is an invitation for someone to take it.
- Sign up for Informed Delivery at USPS.com This service sends you an email every day you are getting letter mail or packages (except Sunday). It includes a scan of the envelope for letter mail. You can also get notices of packages to be delivered by USPS. The Informed Delivery does not include magazines or flyers.
- Do not put outgoing mail out at night. Your mailbox with the red flag up is a big 'take me' sign to thieves. Wait until the morning to put mail out, take your outgoing mail to the post office, or drop it in the outgoing mail tote in the office.
- Pay your bills online or through automatic payment. It is an adjustment for us seniors to do instead of paying by check, but it is far safer.
- If you MUST write and send a check, some tips from Chase Bank include:
  - Use permanent ink so it is harder to erase
  - Fill out the Payee and Dollar amount space completely, drawing a line to the end of the space
  - Mail checks from the post office
  - Use your bank's mobile app to monitor your accounts and verify the Payee and Amount are what you intended
  - Consider getting your statements electronically as well
- Another option is to get a locking mailbox. Per James, Facilities Manager, these must be no wider than 10", bottom mounted, and black. They can be either metal or plastic. Maintenance staff will install them for you, but residents must purchase the mailboxes themselves. We have had some interest in a particular mailbox that is wide enough to allow receiving prescriptions and boxes the approximate size of check boxes. We are currently getting an order together and will be able to get these mailboxes at a discounted price by buying in bulk. The cost per mailbox will be \$97. Please contact Diane Greer @ 661-706-1669 or Diane.M.Greer@gmail.com to order one.

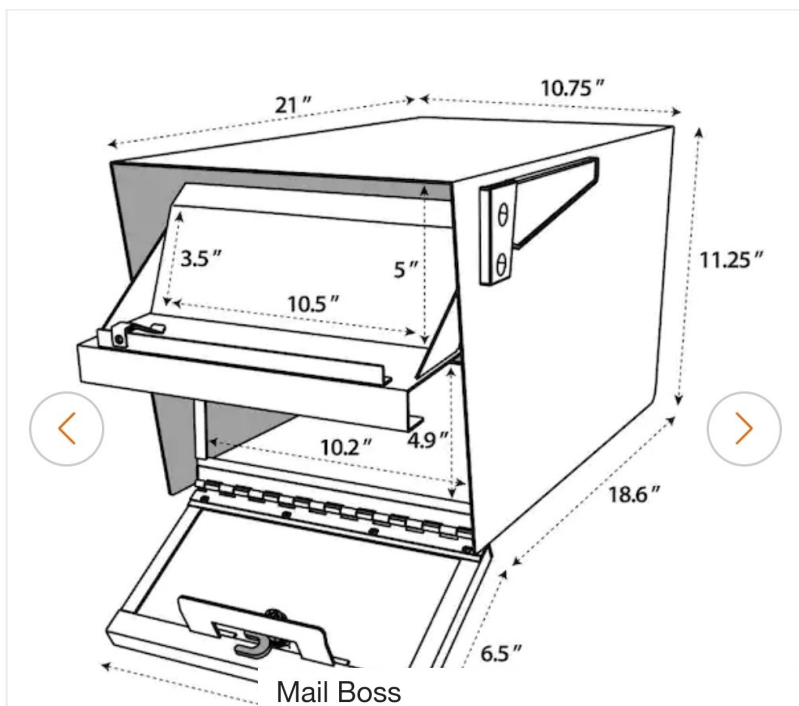

10.4' **Mail Manager Locking Post-Mount Mailbox with High Security Reinforced Patented Locking System, Black**

★★★★★ (721) ✓

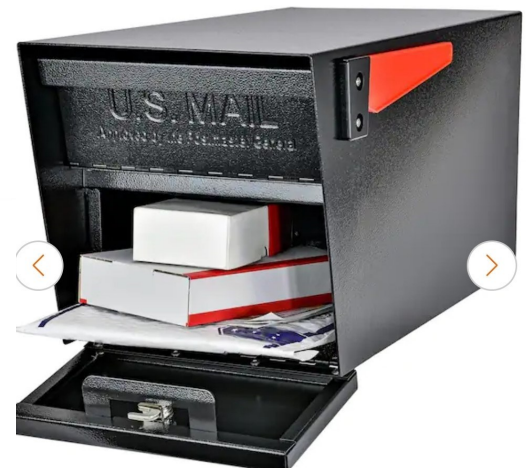

## **RHODY DRIVE REALIGNMENT AND IMPROVEMENT PROJECT UPDATES**

During April K&E Excavating started to move on the Rhody Drive Project. This included finishing cleaning up and grubbing the project area, widening of the east side of Rhody Drive, excavating related to the retaining walls, and removing existing utility poles. They have also completed the new water line installation and one of the retaining walls, installed the irrigation system for the landscape planter for the overlook area. They are installing stormwater infrastructure, installing new water lines and water services and meters for the service is transferred to the new water main, widening the road base, and began construction for the realignment of New Hope Lane. Central Lincoln PUD crews have also been in the area setting the relocated utility poles.

**With the construction beginning to realign and reconstruct New Hope Lane, access to Oregon Coast Humane Society and the Lane County Transfer Station will be available, however, there will be flaggers staged to control traffic.**

**Motorists can expect some delay in entering and exiting New Hope Lane.**

Access to Rhododendron Drive north of 9<sup>th</sup> Street is restricted except for residents of Greentrees Village and Wildwinds and their guests or for any business to the Lane County Transfer Station and the Oregon Coast Humane Society. If you have business at either of these places, please adhere to the flaggers to keep the crews and public safe during construction.

If you need to get to 35<sup>th</sup> Street you must use the alternate route, use 9<sup>th</sup> Street and then Kingwood Street or use Hwy 101, although that will start getting pretty busy soon with the Spring/Summer visitors.

City of Florence Updates and Diane Greer



## **Services**

- Fences • Decks
- Flooring • Tile
- Interior Painting
- Custom Woodwork
- General Repairs
- Fixture Updates
- Roof Treatments
- Power Washing

**541-991-3074**

*CCB#233952 Licenced, Bonded, & Insured*



## IN PRAISE OF READING AND A HANDY LIBRARY

Whether it's been years or hours since you last read a book, consider this: reading is not only pleasurable, but is believed to reduce stress, improve concentration, enhance knowledge, and increase creativity.

Researchers have found that people who spend a few hours a week reading books live longer than those who don't read, or read only magazine or newspaper articles.

At Greentrees, we have a small clubhouse library. There are no due dates, no fines, and the hours are convenient. Please drop by and take a look at what's available.

The mass market (small) paperbacks are in two large bookcases, divided into genres. Each genre is labeled and shelved alphabetically by author. There are small sections of Nonfiction, Science Fiction, and Western, a large section of Fiction, then Christian Romance series. Opposite is a large section of Mystery, and an even larger section of Romance.

The hardbound books and larger paperback books are shelved as Fiction, followed by Biography, Memoir, and History, and finally, General Nonfiction, all alphabetical by author.

One basic rule to follow, whether returning or donating books: do not re-shelve them, but leave them on the table for the library volunteers to do so.

George and I have worked all our lives with books and libraries. We are delighted to have Kate Melpass, a volunteer at the Siuslaw Library, join us — she will have charge of the hardbound and large size paperbacks.

Happy reading!

Jan Durant

## HABITAT FOR HUMANITY WOMEN BUILD

The weekend of April 19<sup>th</sup> and 20<sup>th</sup>, women in the city of Florence came together for the annual Women Build. Florence Habitat For Humanity just recently finished a home, so we spent 2 days building 4 flower benches, 2 chairs, and 4 small benches to be sold at the Habitat Restore. The proceeds from the benches go into the Women Build fund for next year.

The build had many participants from GTV. Debra Baxter and I are on the committee of 8 or 9; we help choose the dates, logo, shirt color, and projects to be built, as well as working on the projects. A shout out to Lou Manzi for providing lunch for about 20 of us on Friday. Thanks to Sam the home owner for serving us lunch on Saturday.

Our very own GTV ladies showed up ready to work and learn new skills on both days. Some handled tools for the first time and a few had some experience. Your neighbors were carrying lumber, running the chop saw, drills and screw guns to get the job done. Shout out to Diane Greer, Diana Lindsley, Lanette Manzi, Jo Mallo-



ry, Linda Smith; everyone did a great job and fun was had by all. Since 1991, Habitat's

Women Build volunteers have come together from all walks of life to build stronger, safer communities. **Women Build opportunities are available across the U.S.**, and any woman or person who wants to learn how to build or repair a home is invited to join.

Women and children are the most likely to be affected by poor living conditions, and these events provide the opportunity for women to take a **proactive step in serving their communities**. Women Build is also a terrific way to **involve your friends and family** of all ages in crucial work with a lasting impact. You can also come alone and make new friends; the atmosphere is collaborative and friendly!

Shanti Chagnon

### Calling all walkers and runners! It's Rhody Run time!

You can be a part of the fun by participating in the run/walk, volunteering, or by lining the streets to cheer on the participants!



5K/10K Run/Walk  
Saturday, May 18, 2024 9:00 am

For more info visit [florencehabitat.org](https://florencehabitat.org)



## PET OF THE MONTH

The new Pet of the Month will be featured by the Oregon Coast Humane Society (OCHS). Our wonderful pet this month is Millie. Sweet Millie arrived in our care after her owner passed away. She lived with another dog who has already been adopted, and now it's Millie's turn. She is 33 pounds, 12 years old, and a low energy gal who enjoys cuddling on the couch more than a walk! If you'd like to help Millie enjoy her golden years with YOU, stop by Oregon Coast Humane Society to meet this special boy. Or see our website for other animals to adopt or foster at [oregoncoasthumanesociety.org](http://oregoncoasthumanesociety.org)



If you need help planning for your animals in case they outlive you or you can no longer take care of them, ask for information about A Plan for My Pets so you can speak for your pets even after you're gone.

OCHS contact info: 541-997-4277

**FLORENCE ELECTRIC INC.**  
**TYLER SMITH**  
OWNER  
**971.344.8793**  
FlorenceElectric@Protonmail.com  
www.florenceoregonelectrician.com  
Licensed • Bonded • Insured  
CCB# 234195

### OFFICE CONTACT INFORMATION

**OFFICE HOURS:** Mon.-Fri. 9-12, 1-3

CLOSED ON HOLIDAYS

**OFFICE PHONE:** 541-997-8674

**OFFICE FAX ONLY:** 541-997-6018

**EMAIL:** [greentreesvillagehoa@gmail.com](mailto:greentreesvillagehoa@gmail.com)

**MAINTENANCE PHONE:** 541-997-1371

## 117th ANNUAL RHODODENDRON FESTIVAL “RHODY DAYS” HIGH TIDES & GOOD VIBES

**MAY 16-19, 2024**

### A Tradition for All:

For generations, families have cherished the Florence Rhododendron Festival—a tradition of carnival thrills, showcasing rhododendrons, displaying classic cars, participating in parades, and savoring the delights of Old Town’s shopping and dining scene. It’s an Oregon institution, a celebration where memories are made.

### Attractions:

- [Rhododendron Court Coronation](#) - May 11
- [Carnival by Davis Shows](#) - May 16-19
- Free Shuttle Service Provided by [Three Rivers Casino!](#)
- [Let It Ride Motorcycle Poker Run](#) benefiting American Legion Veteran programs.
- [Rhody Days Arts Festival](#) - May 18 & 19
- [Rhody Run & Walk](#) - May 18
- [Rhody Classic Car Show 'n' Shine](#) - May 18
- Rhody Car Cruise 6pm May 18 - Coast Radio Classic Car Cruise in Old Town Florence.

**Grand Finale:** Spectacular Floral Parade through Historic Old Town - May 19 at Noon.

For more details and inquiries, contact Chamber of Commerce at 541-997-3128.

Florence Area Chamber of Commerce

### The Village Voice is A Publication of Greentrees Village, Inc.

Editors: Diane Greer & Diana Lindsley

Email: [gtvwebmaster57@gmail.com](mailto:gtvwebmaster57@gmail.com)

Contributing Members: Carley Scibetta, Jim Negri, Diana Lindsley, Kristel Buechner, Bonnie Costa, Jan Durant, Shanti Chagnon, Nancy O'Neill, Nick Woodworth, Diane Greer, and OCHS

Photos: Mike Cox, Nancy O'Neill, Diane Greer, OCHS, and City of Florence

Advertising: Diane Greer (661) 706-1669

© Greentrees Village Voice, 2024 by Greentrees Village, Inc. and cannot be reproduced in whole or in part without the express written permission from the publisher. Greentrees Village does not endorse or recommend third party websites, products, or services.



# EXPERIENCE SHOREWOOD SENIOR LIVING:



INDEPENDENT LIVING AT ITS BEST!

ACTIVITIES, EXERCISE CLASS, ARTS & CRAFTS,  
A MEAL, HAPPY HOUR & LIVE MUSIC + MORE!



## CALL TODAY! 541.997.8202

ASK FOR DETAILS OR TO LET US KNOW WHEN YOU WOULD LIKE TO JOIN US!

# Shorewood

## SENIOR LIVING

Guided by goodness, loyalty, faith, and fun

541.997.8202

sayhello@shorewoodsl.com  
1451 Spruce Street  
Florence, OR 97439  
shorewoodsl.com

 a Compass Senior Living  
Community





# May

2024

Sunday	Monday	Tuesday	Wednesday	Thursday	Friday	Saturday
			<b>1</b> 1 PM Bridge	<b>2</b> 10 AM Music Jam 3:30 PM Yoga	<b>3</b> 1 PM Knit & Crochet Groups	<b>4</b> 5 PM Game Night
<b>5</b> 10 AM Papercrafting / Scrapbooking	<b>6</b> 12:30 PM GERT Radio Test 1 PM Bunco	<b>7</b> 1 PM Card Exchange	<b>8</b> <b>Pool Closed</b> 1 PM Bridge 1 PM Comms Committee	<b>9</b> 10 AM Music Jam 1 PM GERT 1 PM ACC 3:30 Yoga	<b>10</b>	<b>11</b> 1 PM District 4 & 5 meeting 5 PM Bingo (Play starts at 6 PM)
<b>12</b> <b>Mother's Day</b> 1 PM Mother's Day lunch	<b>13</b>	<b>14</b> 10 AM Property Committee 10 AM Senior Moments Coffee Club	<b>15</b> 10 AM Finance Committee 11:30 Lunch Out 1 PM Bridge	<b>16</b> 10 AM Music Jam 3:30 PM Yoga	<b>17</b> 10 AM Quilt Group	<b>18</b> 2 PM District 3 meeting 5 PM Game Night
<b>19</b>	<b>20</b> 10 AM Activity Committee 1 PM Bunco	<b>21</b> 1 PM Board of Directors Meeting	<b>22</b> 1 PM Bridge	<b>23</b> 10 AM Music Jam 2 PM Book Club 3:30 PM Yoga	<b>24</b> 5 PM Potluck	<b>25</b> 5 PM Bingo (Play starts at 6 PM)
<b>26</b>	<b>27</b> <b>Memorial Day</b> <b>Office Closed</b>	<b>28</b>	<b>29</b> 1 PM Bridge	<b>30</b> 10 AM Music Jam 3:30 PM Yoga	<b>31</b>	5 PM Bingo (Play starts at 6 PM)

## Event locations

Daily (weekdays):

Water Aerobics, at the Pool, 8 AM

Mon /Wed / Fri:

Pickle Ball, at the court, 8:30 AM

Exercise Class, Rec Hall, 10 AM

Tai Chi, Rec Hall, 9 AM

Rec Hall:

All District Meetings

Board Meeting

Scrap Booking Group

Bunco

Card Exchange

Potluck

Game Night

Coffee Room:

Bridge Club

Senior Moments Coffee Club

Multi-Purpose Room:

Property Committee

Finance Committee

Communications Committee

Activity Committee

Quilt Club

Music Jam

GERT

Knit & Crochet Group

Conference Room:

ACC Committee

## Tidbits

**IMPORTANT REMINDER: The date for payment of dues without incurring late fees is the 25<sup>th</sup> of the month.** Payments made on the 26<sup>th</sup> or later will incur a \$25 late fee as well as interest.

**HOA Fees:** Reminder that the HOA fees for 2024 are **\$270 per month** or \$3,240 per year. You can pay your dues monthly, quarterly or annually

**Recycling:** The Activities Committee collects bottles and cans with deposits. All the funds go to the Activity Committee to offset the costs of events. There is a blue barrel in the Rec Hall to collect your donations. We thank you for your help in supporting GTV events.

**New Residents** are reminded they need to check in with the Office within 7 days of moving in to be registered and obtain the Welcome package.

**Dumpster Use:** It's getting to be that time of year when we are cleaning up yards and getting yard debris. A reminder that **ONLY** yard debris should be in the dumpsters (no trash or plastic bags). There is a fine for doing that. Branches should be kept to under 3 inches and 3 feet long.

**Directory info:** Is your directory information correct –names, phone numbers and email address? The Office needs correct information in order to contact you.